



2024 Production Rider

TABLE OF CONTENTS

Personnel and Contacts
General Requirements
Sound Production
Lighting Production
Stage Plot
Hospitality
Advance Questions

PERSONNEL and CONTACTS

Executive Director

Tara W. Johnson

Office: (608) 658-4907 – Tara.Johnson@kidsfromwisconsin.org

Contact for Marketing and Publicity needs, Ticket Sales, Financial questions

Programming Operations Director

Peggy Morgan Strimple

Office: (414) 266-7067 - Peggy.Strimple@kidsfromwisconsin.org

Contact for Contracts, Pricing, Bookings

RYD Program Manager/Tour Assistant

Carley Kolsch

Office (414) 266-7067 Carley.Kolsch@kidsfromwisconsin.org

Contact for Realize Your Dream workshops and registration, Lodging/Home Stays, Meals, Troupe Member inquiries

Production Manager/Tour Manager/A1

Matthew Pea

Mobile: (920) 210-6021 – Matt.Pe@kidsfromwisconsin.org

Contact for Tech Questions, Schedule and Itinerary of the Performance day, Facility Accommodations and Requirements, Tour Staff relations

Website and Social Media

www.kidsfromwi.org

www.facebook.com/kidsfromwi

Twitter & Instagram: @KIDSfromWI

Address

Kids From Wisconsin
640 South 84th Street Suite 522
Milwaukee, WI 53214
(414) 266-7067

GENERAL REQUIREMENTS

Stage

Purchaser shall provide:

- An industry standard, professional quality, uncarpeted performance space of 40'(W) x 32' (D) or larger. Wing space and backstage cross space is in addition to the 40' x 32' dimensions.
- A backstage cross, either behind a curtain on stage or in a hallway, is required.
- The backstage cross and wing space require functional safety lighting for the performers if these locations are exceptionally dark during the performance.
- Stairs placed approximately 10 ft from upstage edge of the performance area, stage left and stage right, to access the stage level if necessary, regardless of backstage cross location.

Stage Preparation

The stage should be clear and swept clean prior to scheduled load-in time. Please have trash cans available near the stage.

Risers

Platform risers are preferred upstage for the band (see diagram and photos below). KFW will provide dance platforms.

Work Lights

There should be adequate work lights located throughout the show site to light the stage, wings, loading dock area, house, and mix position when needed.

Outdoor Venues

An outdoor stage must meet the above listed stage requirements, plus:

- Stage size: 40'W x 32'D, which includes wing space
- Backstage cross, and other performer paths, must be safe for the performers
- Any damp, non-paved surface (grass, clay, gravel, etc.) in the performers off-stage paths, such as the backstage cross, need to be covered with runners to ensure performer safety and prevent costume damage and mud/grass/water from being transferred to the stage via performers shoes. Please contact the Production Manager if you are unsure about this.
- If there is not a paved path to the stage from where the equipment truck unloads, a plywood road needs to be laid for cases to roll across (due to their weight, most of our cases cannot be carried and will likely sink in damp grass or clay).
- For the performer's safety, the stage must be able to support 36 members for safe, energetic choreography that may include partnering lifts and all performers jumping or swaying simultaneously. Please consult with your stage supplier to assure the stage is supported with adequate bracing and footings so the stage does not sway, stage pieces do not separate or become uneven, and the legs do not sink into the ground. The stage must adhere to the specifications listed above. Any deviation from these specifications must be agreed upon between Purchaser and Artist prior to acceptance of the KFW Tech Rider.
- Refer to contract for weather related information

If required stage provisions cannot be met, they must be cleared with the KFW Production Manager prior to event booking.

Times and Running Order

The artists require access to the stage, seating area, and dressing rooms for a total of five hours before and 90 minutes after show time for set-up, sound check, rehearsal, and strike. The performance will start as close to the time agreed upon in the show contract as is possible. Our daily schedule accounts for the house opening approximately 30 minutes prior to the listed show time. If doors are to open prior to this, please note this in your contract (outdoor venues are taken into consideration already). We will not switch our time slot or position on the day of the event unless agreed upon between purchaser and artist representative(s).

AUDIO PRODUCTION

General Information

KFW is self-contained when it comes to audio production, including sound engineers and backline. The KFW Tour Staff oversee the set-up and production of the show. All set-up and strike work is done by KFW members. If an in-house audio system is available for use, please discuss this with the Production Manager during the show advance.

Mix Position

Ideally, the mix position will be located wherever the guest mix position is in the theater. Our console is housed in a flip case, so placing our console within the theater seat rows may not be an option. If a guest engineer position does not exist, please contact the Production Manager/Tour Manager to help determine a suitable location. If venue requires additional in-house fills (delays, side-fills, etc.), XLR sends can be placed at our mix position or our main stage rack, which will sit either DSR or DSL in the wing space. There also needs to be an 120V/15A electrical outlet near the FOH location.

For outdoor performance spaces, the mix position needs to be located on a smooth, level surface 50' - 100' in front of the stage. We will place a 10' x 10' tent at this location to keep our audio console out of the sun and dry in the event of rain. If there is not a suitable power source nearby, we will run a power cable from stage, along with our snake, to the mix position. We also carry approximately 80' of cable ramps to cover cables running to the mix position.

Power

We travel with a power distribution system that requires 3-phase/5-wire camlock tails, 50A CS twist-lock, or a 50A range plug for power hookup. The cable distance from the tie-in point to a downstage corner needs to be a max of 125' with cable paths outside of public walkways. If the intended cable path crosses a public walkway, the venue or host *must* provide cable ramps (our cable ramps cannot hold feeder cable or 50A cable) or other sufficient cable covers. We will be traveling with one (1) 50' section of 2 AWG 5-wire feeder cable with cams and longer runs of 50A cable with CS twist lock connectors as well as the necessary breakout boxes. A venue-provided electrician is required to tie tails into the electrical panel. If the electrical panel is further than 125' from a downstage corner, the venue/host may provide additional feeder cable that is 2 AWG or larger to extend from where our feeder reaches, or provide electricity another way (see below). If tails cannot be provided at the panel, we will have a set the electrician can use. Tails need to be tied-in prior to or upon our arrival. If our set of tails is being used to tie into the panel, they need to be removed from the panel by the venue electrician approximately 30 minutes after our show has ended.

If your outdoor venue does not have an electrical panel within reach, a minimum of 20kW (25kV•A) diesel generator with 3-phase cam locks or 50A CS twist lock connections needs to be provided. The generator must be tested, and electricity production confirmed, prior to our arrival. An electrician does

not need to tie in power for us to a generator that meets the specs described above. The generator should be located 100'-125' from a downstage corner to reduce noise and to be within reach of our cabling. Additional feeder cable can be rented, by the host/venue, if the generator needs to be located further away. If cables need to cross a public walkway, cable ramps need to be provided by the venue or host.

PLEASE NOTE: Standard 15A or 20A, 120V, wall outlets may be used, however this is not preferred as we may not have enough cabling to reach the different locations (minimum 4 circuits on stage for sound + 1 at the mix position). Please direct power concerns and/or questions to the Production Manager.

LIGHTING PRODUCTION

Lighting Requirements

A light plot will be sent out to tech contacts during show advances or the week prior to our premier show, whichever comes second. If the venue is unable to follow the lighting plot provided, a general warm and cool wash may be used to light the performance space (see diagram). KFW will gladly use a house plot if it meets or exceeds what we are aiming for. A knowledgeable lighting technician, with the authority and means to refocus lighting fixtures, should be available when KFW arrives and throughout set-up. The KFW Technicians will work with this individual and give final approval of the lighting plan and set-up. The KFW Lighting Technician is responsible for operating the lighting board, calling spots during the show, and will assist with the light hang/focus, if needed, once on site.

Kids From Wisconsin travels with the following fixtures:

- (4) Elation Platinum Spot II LED (approx. 35.3lbs each)
 - (6) Chauvet R2x Wash (approx. 22.8lbs each)
 - (1) American DJ hazer (floor based)
- ** stage weights should be available for counter-weighting if necessary**

Follow spot(s) may be used (if available) at Production Manager's discretion (if run by experienced operators).

STAGE DIAGRAM EXAMPLE and PHOTO

- Total riser width from SR to SL can be 40'
- Center drum riser is 8'x8' and can be 24"H if available
- 8" riser on SL side can be cut if necessary

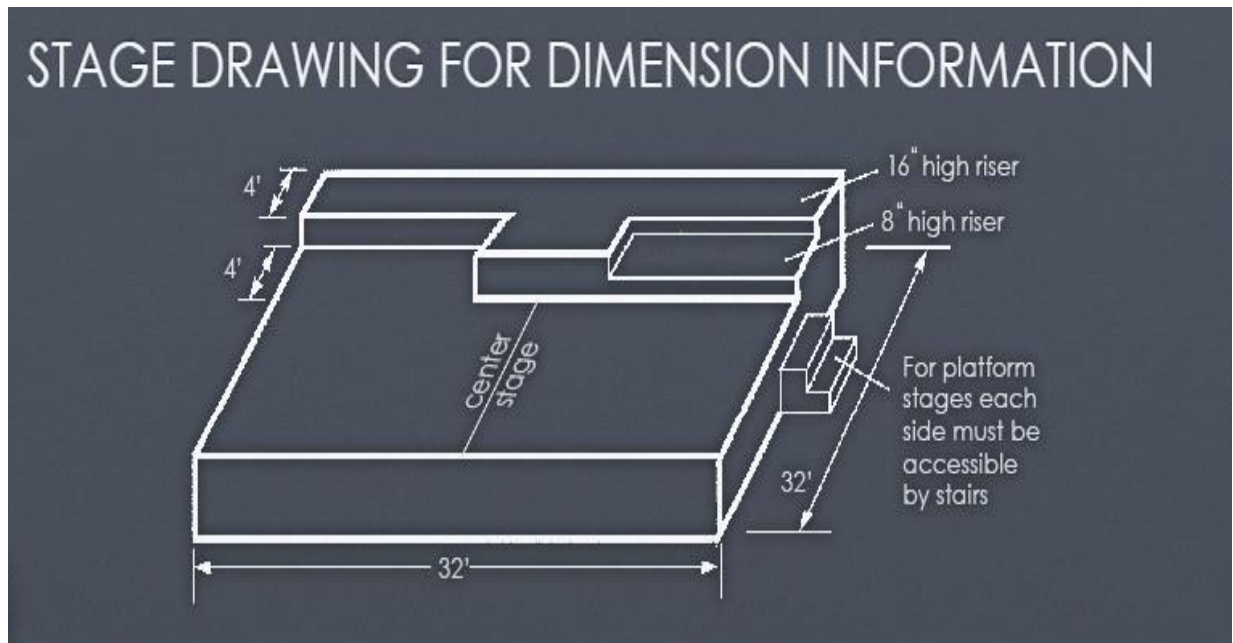

Photo below shows 24" drum riser, 16" for remainder of band width, and no 8" riser on the SL side



Set up in Lobby

8' table and two chairs for KFW merchandise.

HOSPITALITY INFORMATION

Water

We require access to clean drinking water at each venue. This can be either a tap for us to fill our water cooler, or water bottles you supply. Regardless of which, we ask that ice is available for us.

Dressing Rooms

We require access to two (2) dressing rooms, close to the stage and large enough to accommodate 15 performers each. Both rooms should contain mirrors, clothing racks, 10+ chairs, adequate lighting, and electrical circuits separate from stage power. We also need access to a third dressing room, which can be further away, for most of our instrumentalists. It can be something like an music room, small dance studio, or rehearsal space.

Rooms should be clean and free of clutter. If a dressing room has windows that would allow others to see in, they need to be covered with something non-transparent prior to our arrival. If you have areas that you do not want the performers to enter, please make the tour staff aware.

Single Event - Outdoor Dressing Facilities

- ***We travel with our own tents but need to ensure space is available surrounding the stage for them (10'x10' and 10'x20').***
- In case of extreme temperature conditions, an easily accessible air-conditioned room or building that is unlocked with access to restrooms and shelter for all tour members before, during and after the performances.

Multiple Event - Outdoor Dressing Facilities

Required facilities will need to be secured, air conditioned, and with the same amenities as above. Any KFW equipment will also need to be protected from the weather and secured when we are not on site.

Overnight Accommodations

The following information are only for those who are requested to provide housing for the Kids From Wisconsin. **Once troupe members are confirmed, tentatively April 1, 2024, we will be able to provide more accurate rooming information.**

Lodging Option (up to 36 troupe members/5 staff + bus driver)

- In searching for lodging, reach out to hotels and college dorms for local support and nonprofit organization pricing. You may be surprised how willing hotel managers will work with you on rates or sponsorship. Be sure to explain bringing the show to their community increases revenue in your area. We will be happy to mention their support at the end of our show and sing a thank you song to them at our departure.
- Please be sure hotels are in safe quiet areas of your community, not near any adult entertainment, late night bar or tavern.
- We may ask you provide a hotel for our bus driver
- Spaces needed:
 - 2 troupe members to a room is very generous and appreciated. However, to be cognizant of cost we understand 3-4 to a room may need to occur *
 - *If 3-4 to a room, we do need a separate space at the hotel where the troupe can hang their costumes to dry overnight (like a ballroom or meeting room that can be secured).
 - Though not mandatory, please try to choose a hotel that has breakfast included.
 - We insist hosts give your cell/home phone numbers to the night staff and tour staff, should they need any assistance during the night or the morning
 - Tour staff rooms are also needed. Again we like to be able to give them their own room, but understand if they need to share. Up to 2 per room and/or 1 per bed is appreciated.

“Home Stays” Option (up to 36 troupe members)

Home Stays with the Kids From Wisconsin have been part of the troupe members touring experience for over 56 years. Many alumni have recalled their home stays as being one of the favorite parts of touring and we consider it another connection to the communities we visit. If considering this option, hosts are responsible for either arranging and contacting local families in their community for home stays. It's a big job, so please consider having an assistant help. A good place to start finding families willing to host are high school performing arts departments, dance or music studios or other performing art organizations where families/youth are involved. Our troupe members would love to spend time with young performers in a host family environment!

What is a host family? Host families are volunteers who welcome two or more Kids From Wisconsin troupe members into their home and provide overnight accommodations for a relaxing and restful night. More information located on next page.

How does a host family sign up? Kids From Wisconsin provides a sign up link to begin the application process. The application will have questions about how many performers they can take in, how many beds can be provided, if they have pets, be able to accommodate any allergies, etc. Home Stay Host applicants will also be informed that their names and information will be run through Wisconsin Circuit Court Access (formerly CCAP) and the Wisconsin Sex Offender Registry. They will be contacted by our staff once approved.

A HOST FAMILY MUST CLEAR WITH OUR ORGANIZATION 2 WEEKS PRIOR TO OUR PERFORMANCE DATE IN THAT CITY

Home Stay Information for Hosts:

- There must be a minimum of two troupe members per home.
- The host family needs to provide transportation from the show site to their home and back to an agreed upon meeting location (usually the show site or staff hotel) the next morning.
- The host families should provide the troupe members with a bed (including bedding and pillow), towels for showering, and a place to hang up and air out costumes.
- Two members can share a double bed.
- If a host family cannot provide traditional beds for troupe members to sleep in, alternatives include a pull out sofa/sleeper, cot, air mattress, or similar. Please, no couches, recliners, beanbags, or having them to sleep directly on the floor.
- Performers often appreciate a snack at night after the show.
- Food allergies and intolerances can be found on our rooming list, sent to you electronically approximately two weeks prior to show.
- Animal allergies can be found on the rooming list, sent to you electronically approximately two weeks prior to the show - please accommodate to the best of your ability. We will do our best to avoid animal allergies based on responses in the home stay host application.
- Host families should provide breakfast before transporting troupe members to designated meeting location, usually between 7:30 - 9:00 am. Meeting location is determined prior to everyone leaving the show site the previous evening.
- Approximately two weeks prior to our performance in your area, the Tour Assistant will call to confirm the final number of troupe members who need housing.
- Host families will connect with troupe members 60-90 minutes following the conclusion of the show.

On behalf of Kids From Wisconsin, thank you for your donation of time and energy through organizing housing!

Catering Ideas

The Kids From Wisconsin greatly appreciate your generosity in providing our pre-show meal(s). Listed below are some menu items enjoyed by the KFW troupe. Please help us accommodate our performers who are allergic/intolerant to certain foods, vegetarian, gluten free, and dairy free. A list of dietary needs will be provided to you by the Tour Assistant as we get close to the performance date. It is greatly appreciated if you inform the Tour Manager/Tour Assistant of the intended meal. This is to make sure the troupe is NOT eating pizza 5 days out of a week. Thank you!

Menu items enjoyed by the troupe, especially before a show, are foods that are healthy, light, lots of protein options and non-greasy.

- BBQ food - brats, hotdogs, hamburgers, etc.
- Hot sandwiches - beef, turkey, chicken, pulled pork, etc.
- Chicken or veggie wraps
- Quesadillas
- Beans and rice
- Pasta with a light sauce or pasta salad
- Potato Bar with toppings including a protein
- Taco Bar - tacos, burritos (beef, chicken or fish options)
- Fresh Fruit
- Fresh Vegetables or leafy salads
- Assortment of chips
- Water
- Fruit juice
- Gatorade
- Cookies
- Bars

Something in addition to water is appreciated for a meal. Lemonade or Gatorade are great options.

ADVANCE QUESTIONS

Please answer the following questions:

- Where will we park any transportation (bus, straight truck, personal vehicles)?
- Where will we load in through? Describe the load-in (i.e. stairs, elevators, ramps, etc.). Stairs must be avoided everywhere unless agreed upon by the Production Manager prior to load in. ***We do have road cases that will not fit through a standard width doorway, so ideally equipment will enter through an overhead doorway or a double-wide doorway (no post).***
- How many dressing rooms are available and where are they located?
- Where are the nearest restrooms located?
- Where is the closest drinking water source located?
- Do you have wireless internet available? If so, please provide any necessary log-in information.

Please provide the following:

- A parking map (can be hand drawn) with detailed instructions including road names.
- Contacts for venue sound, lighting, and house personnel.
- Any information you believe will be necessary for a successful show experience in your venue.

The KFW Production Manager and/or Tour Manager will reach out with additional questions/information as your show approaches.

Payment

Payment should be provided as agreed in contract. Checks should be made payable to: KIDS From Wisconsin and submitted to the KIDS office by date on contract, but no later than the day of the performance. If you are paying on the day of the show, please give the check to the KIDS Program Manager/Tour Assistant, or other tour staff member if they are not present. Any adjustments to payment arrangements must be approved by the KIDS Executive Director.

**Send checks to:
KIDS From Wisconsin
640 S. 84th St. Suite 522
Milwaukee, WI 53214**